

COMPLIANCE INFORMATION

UL Listed
C-UL Listed (Canada)
CISPR/EN55022 Class A

FCC Regulations

This equipment has been tested and found to comply with the limits for a class A digital device, pursuant to part 15 of the FCC rules. These limits are designed to provide reasonable protection against harmful interference when the equipment is operated in a commercial environment. This equipment generates, uses, and can radiate radio frequency energy and, if not installed and used in accordance with the instruction manual, may cause harmful interference to radio communications. Operation of this equipment in a residential area is likely to cause harmful interference, in which case the user will be required to correct the interference at the user's own expense.

Canadian Regulations

This digital apparatus does not exceed the Class A limits for radio noise for digital apparatus set out on the radio interference regulations of the Canadian Department of Communications.

Le présent appareil numérique n'émet pas de bruits radioélectriques dépassant les limites applicables aux appareils numériques de la classe A prescrites dans le Règlement sur le brouillage radioélectrique édicté par le ministère des Communications du Canada.

European Regulations

Warning

This is a Class A product. In a domestic environment this product may cause radio interference in which case the user may be required to take adequate measures.

Achtung !

Dieses ist ein Gerät der Funkstörgrenzwertklasse A. In Wohnbereichen können bei Betrieb dieses Gerätes Rundfunkstörungen auftreten, in welchen Fällen der Benutzer für entsprechende Gegenmaßnahmen verantwortlich ist.

Attention !

Ceci est un produit de Classe A. Dans un environnement domestique, ce produit risque de créer des interférences radioélectriques, il appartiendra alors à l'utilisateur de prendre les mesures spécifiques appropriées

VCCI Class 1 Compliance

This equipment is in the 1st Class category (information equipment to be used in commercial and/or industrial areas) and conforms to the standards set by the Voluntary Control Council For Interference by Data Processing Equipment and Electronic Office Machines aimed at preventing radio interference in commercial and/or industrial areas. When used in a residential area or in an adjacent area thereto, interference may be caused to radio and TV receivers, etc. Read the instructions for correct handling.

この装置は、第一種特定電波 (国工業地域において使用される) を使用
第一種工業地域での電波障害防止を目的とした情報処理装置等規制標準
生活環境委員会 (VCCI) 基準に適合しております。
従って、住宅地域が大半を占めた地域で使用する時、ラジオ、テレビ
FM/FM2放送等に受信障害を及ぼすことがあります。
取扱説明書に従って正しい取り扱いをして下さい。



CAUTION: RJ connectors are NOT INTENDED FOR CONNECTION TO THE PUBLIC TELEPHONE NETWORK. Failure to observe this caution could result in damage to the public telephone network.

Der Anschluss dieses Gerätes an ein öffentliches Telekommunikationsnetz in den EG-Mitgliedstaaten verstößt gegen die jeweiligen einzelstaatlichen Gesetze zur Anwendung der Richtlinie 91/263/EWG zur Angleichung der Rechtsvorschriften der Mitgliedstaaten über Telekommunikationsendeinrichtungen einschliesslich der gegenseitigen Anerkennung ihrer Konformität.

Trademark Notice

All registered trademarks and trademarks are the property of their respective owners.

Copyright Restrictions

© 1999 TRANSITION Networks.

All rights reserved. No part of this work may be reproduced or used in any form or by any means – graphic, electronic, or mechanical – without written permission from TRANSITION Networks.

Printed in the U.S.A.

33147.A

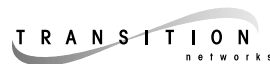

Minneapolis, MN 55344 USA

AUI/10BASE-T Transceiver E-TBT-MC03 USER'S GUIDE

The TRANSITION Networks E-TBT-MC03 transceiver with LinkALERT™ is a media access unit (MAU) that connects the AUI port of any DTE, repeater, or other network device, either directly or through an AUI cable, to an Ethernet™ 10BASE-T device. The Ethernet device is connected to the E-TBT-MC03 through unshielded or shielded twisted-pair copper cable and an RJ-45 connector.

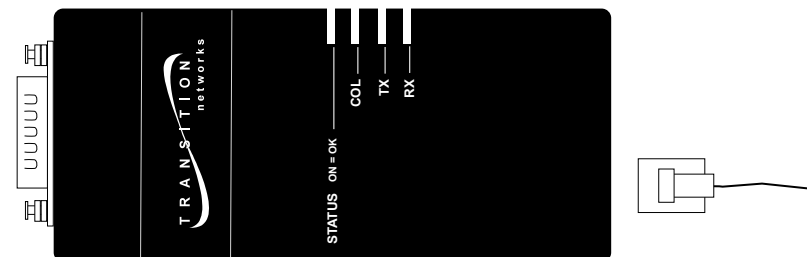

E-TBT-MC03 in the Network	2
Installation	3
Operation	4
Fault Isolation and Correction	5
Cable Specifications	6
Technical Specifications	7
Compliance Information	8

E-TBT-MC03 IN THE NETWORK

NOTE: AUI cable can be used to connect to the transceiver.

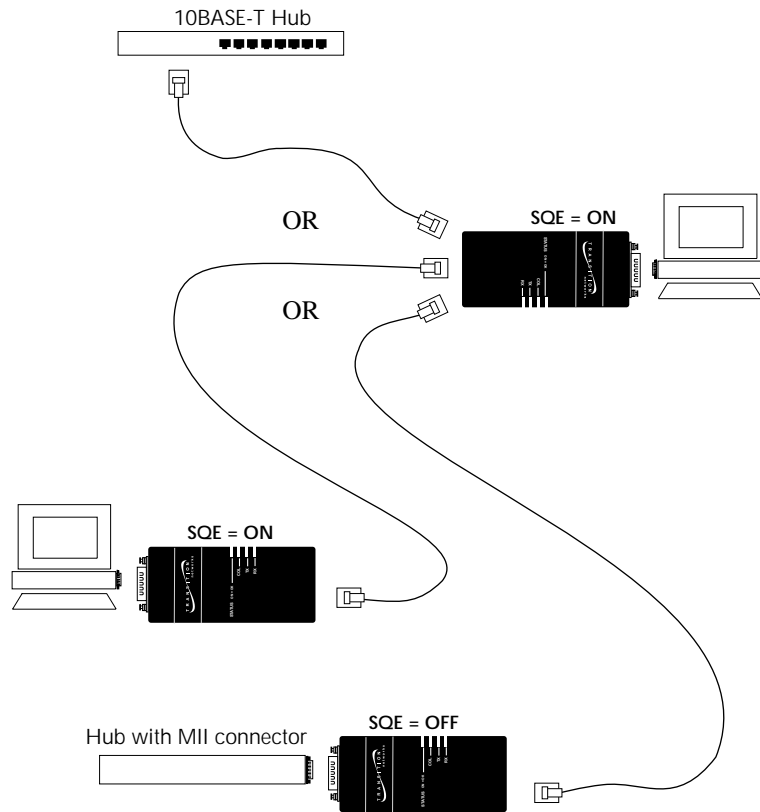

Using LinkAlert™

The LinkAlert™ feature allows the transceiver to pass 10BASE-T-side link faults to the AUI side and to pass AUI-side link faults to the 10BASE-T side.

If the channel does not detect a good link on the 10BASE-T side, the transceiver disables all transmission (including active-idle) on the AUI side AND the **STATUS** LED on the transceiver blinks twice.

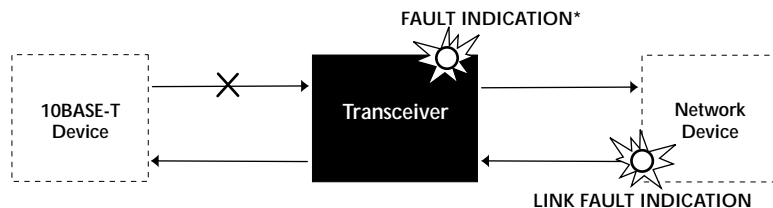

TECHNICAL SPECIFICATIONS

Standards	IEEE 802.3	
Case Dimensions	1.65" x 3.10" x 0.94" (42 mm x 79 mm x 24 mm)	
Weight	3.4 oz. (96.5 g)	
Environment	Temperature:	0-40°C (32° to 104° F)
	Humidity	10-90%, non condensing
	Altitude	0-10,000 feet
Power	11.4 - 16.5 VDC, 75 mA (typical), 200 mA (maximum)	
Warranty	Lifetime	

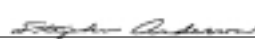
TRANSITION <small>NETWORKS</small>	DECLARATION OF CONFORMITY
Name of Mfg:	Transition Networks 6475 City West Parkway, Minneapolis MN 55344 USA
Model:	AUI/10BASE-T Transceiver
Part Number:	E-TBT-MC03
Regulation:	EMC Directive 89/336/EEC
Purpose:	To declare that the E-TBT-MC03 to which this declaration refers is in conformity with the following standards.
	EMC-CISPR 22: 1985 Class A; EN 55022: 1988 Class A; EN 50082-1:1992; EN 60950 A4:1997; IEC 801.2, IEC 801.3, and IEC 801.4; IEC 950
	<i>I, the undersigned, hereby declare that the equipment specified above conforms to the above Directive(s) and Standard(s).</i>
	August 11, 1999 Date
Stephen Anderson, Vice-President of Engineering	

CABLE SPECIFICATIONS

The physical characteristics of the media cable must meet or exceed IEEE 802.3 specifications.

Copper Cable and Connector

Category 3 or better twisted-pair copper wire is required. Either shielded twisted-pair (STP) or unshielded twisted-pair (UTP) can be used. DO NOT USE FLAT OR SILVER SATIN WIRE.

CATEGORY 3:

Gauge	24 to 22 AWG
Attenuation	11.5 dB/100m @ 5-10 MHz
Maximum Number of Nodes	2 nodes
Maximum Cable Distance	100 meters
RJ-45 Pin-outs	Pin 1=TD+, Pin 2=TD-, Pin 3=RTD+, Pin 6=RD-

Twisted pair connection requires two active pairs configured as straight through. The two active pairs in an Ethernet™ network are pins 1 & 2 and pins 3 & 6. Use only dedicated wire pairs (such as blue/white & white/blue, orange/white & white/orange) for the active pairs.

NOTE: Crossover cable used for transceiver-to-transceiver or transceiver-to-DTE; Straight-through cable used for transceiver-to-hub, switch, or any hub crossed over..

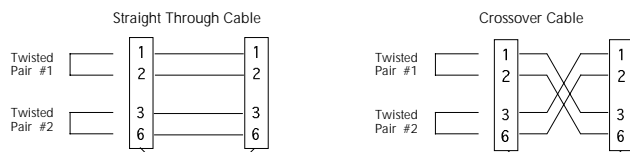

AUI (DB-15) Interface

Parameter	Minimum	Typical	Maximum
Transmit			
Transmit threshold voltage level:	-140mV	-170mV	-190mV
Transmit turn on delay:			100ns
Transmit steady propagation delay:		15ns	50ns
Transmit loop back start up delay:			500ns
Transmit turn off to data idle:	400ns		2100ns
SQE test delay:	0.6 μ sec		1.6 μ sec
SQE test duration:	0.5 μ sec	1.0 μ sec	1.5 μ sec
Receive			
Receive turn on delay:			350ns
Receive steady propagation delay:	15ns	50ns	
Differential output voltage (RX(-/+)):	(+/-)550mV		(+/-)1200
Differential output voltage (col(-/+)):	(+/-)550mV		(+/-)1200
Differential output rise time (RX(-/+), col(-/+)):	4ns		
Differential output fall time (RX(-/+), col(-/+)):	4ns		
Collision			
Time for SQE to deact. after collision:	450ns		700ns
Collision frequency:	8.5MHz		11.5MHz
Collision pulse duty cycle:	40%	50%	60%
SQE test delay:	0.6 μ sec		1.6 μ sec
Jabber activation delay:	20ms	70ms	150ms

INSTALLATION

Set Switches

NOTE: UP enables the indicated function on the 4-position switch located to the right of the 10BASE-T connector and DOWN disables the indicated function.

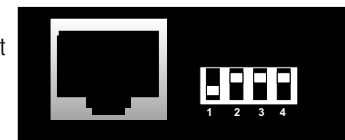

- SQE Test:** Controls SQE test function. Disable this function when connecting to IEEE 802.3 compliant repeaters. Enable this function when connecting to other devices. *Default is enabled (UP).*
- LinkALERT:** Enables the LinkALERT function. With the switch down, the transceiver implements the standard Link Integrity Test. *Default is enabled (UP).*
- Polarity Correction:** Corrects for a receive pair with reversed polarity. In both switch positions reversed polarity is indicated by 5 Status LED blinks. *Default is enabled (UP).*
- Extended Distance:** Increases receiver sensitivity to allow operation with high loss cables or data grade cables longer than 100 meters. NOTE: Do not use this feature unless necessary; *Extended Distance* makes the transceiver more susceptible to plant noise and crosstalk. *Default is disabled (DOWN).*

Install Cable

NOTE: See page 6 for cable specifications and configurations.

NOTE: KEEP TWISTED PAIR RUNS AS SHORT AS POSSIBLE.

- Locate or build 10BASE-T compliant cables with male RJ-45 plug connectors at both ends.
- Connect male RJ-45 plug connector at one end of cable to transceiver RJ-45 jack connector.
- Connect male RJ-45 plug connector at other end of cable to 10BASE-T device RJ-45 jack connector.

Connect to Power

The E-TBT-MC03 is powered through the AUI connection.

OPERATION

After installation, the transceiver should function without operator intervention.

Status LEDs

Use the status LEDs to monitor transceiver operation in the network.

STATUS ON=OK

Steady green LED indicates normal operation.

Link Down: One (1) continuous,

flashing blink indicates no data packet or link integrity pulse being received over twisted-pair.

Local Jabber: Two (2) continuous, flashing blinks indicate AUI packets are too long.

Polarity Reversed: Five (5) continuous, flashing blinks indicate receive pair has the wrong polarity. The transceiver automatically corrects this condition if switch 3 is UP. This warning will continue until the wiring is corrected.

Dark LED indicates NO connection to external power.

COL(lision):

Illuminated amber LED indicates signal collisions on the Ethernet cable.

TX

Flashing or illuminated amber LED indicates packet transmission (AUI to twisted-pair).

RX

Flashing or illuminated amber LED indicates packet reception (twisted-pair to AUI).

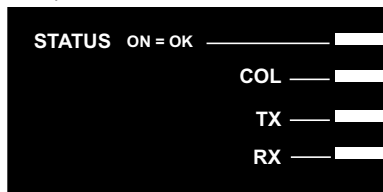

FAULT ISOLATION and CORRECTION

If the transceiver fails, determine the answers to the following questions:

1. Is the STATUS LED on the transceiver illuminated?

NO

- Verify that the transceiver is installed properly in the AUI port and that the DTE device is powered ON?
- Contact Technical Support at (800) 260-1312/(800) 526-9267.

YES

- Proceed to step 2.

2. Is the RX LED illuminated?

NO

- Check twisted pair cables for proper connection.
- Contact Technical Support at (800) 260-1312/(800) 526-9267.

YES

- Proceed to step 3.

3. Is the TX LED illuminated?

NO

- Check AUI cables for proper connection.
- Restart the workstation to restart the initialization process.
- Contact Technical Support at (800) 260-1312/(800) 526-9267.

YES

- Contact Technical Support at (800) 260-1312/(800) 526-9267.