

MEDIA CONVERTER TECHNICAL SPECIFICATIONS

Standards	IEEE 802.3	
Case dimensions	3.9" x 3.0" x 1.0"	(99mm x 76mm x 25mm)
Environment	Temperature:	0-50°C (32° to 122° F)
	Humidity	10-90%, non condensing
	Altitude	0-10,000 feet
MTBF	E-CX-TBT-04	48,000 hours
	E-CX-FRL-04	47,000 hours
Warranty	5 years	

Power Supply Requirements Replace power supply with only the equivalent input rating (see below) and output rating (regulated 9VDC at 0.5 A).

<u>TN PN</u>	<u>Requirement</u>	<u>Location</u>
3517	240 volts, 50 hertz	United Kingdom
3516	230 volts, 50 hertz	Europe
3518	120 volts, 60 hertz	USA/Canada/Mexico
3514	100 volts, 50-60 hertz	Japan
3515	240 volts, 50 hertz	Australia



CAUTION: RJ connectors are NOT INTENDED FOR CONNECTION TO THE PUBLIC TELEPHONE NETWORK. Failure to observe this caution could result in damage to the public telephone network.

Der Anschluss dieses Gerätes an ein öffentliches Telekommunikationsnetz in den EG-Mitgliedstaaten verstößt gegen die jeweiligen einzelstaatlichen Gesetze zur Anwendung der Richtlinie 91/263/EWG zur Angleichung der Rechtsvorschriften der Mitgliedstaaten über Telekommunikationsendeinrichtungen einschliesslich der gegenseitigen Anerkennung ihrer Konformität.

Compliance Information

UL Listed
C-UL Listed (Canada)
CISPR/EN55022 Class A

FCC Regulations

This equipment has been tested and found to comply with the limits for a class A digital device, pursuant to part 15 of the FCC rules. These limits are designed to provide reasonable protection against harmful interference when the equipment is operated in a commercial environment. This equipment generates, uses, and can radiate radio frequency energy and, if not installed and used in accordance with the instruction manual, may cause harmful interference to radio communications. Operation of this equipment in a residential area is likely to cause harmful interference, in which case the user will be required to correct the interference at the user's own expense.

Canadian Regulations

This digital apparatus does not exceed the Class A limits for radio noise for digital apparatus set out on the radio interference regulations of the Canadian Department of Communications.

European Regulations

Warning

This is a Class A product. In a domestic environment this product may cause radio interference in which case the user may be required to take adequate measures.

Copyright Restrictions

© 1996, 1999 TRANSITION Networks.

All rights reserved. No part of this work may be reproduced or used in any form or by any means – graphic, electronic, or mechanical – without written permission from TRANSITION Networks.

Trademark Notice

All registered trademarks and trademarks are the property of their respective owners.

7380.E

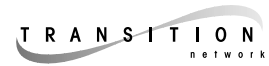

Minneapolis, MN 55344 USA

10BASE-2/10BASE-T 10BASE-2/10BASE-FL

Media Converters

E-CX-TBT-04

E-CX-FRL-04

USER'S GUIDE

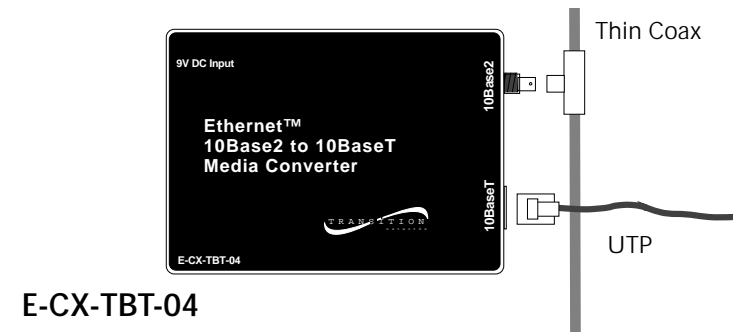

E-CX-TBT-04

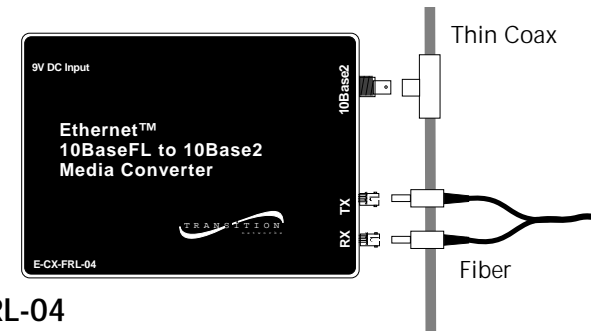

E-CX-FRL-04

MEDIA CONVERTER CONNECTORS, SWITCHES and INDICATORS

CONNECTORS

10BASE-T	RJ-45 connector
10BASE-2	BNC connector
10BASE-FL	TX, RX ST type connectors (SMA type available upon request)

INDICATORS

Power	Steady green LED indicates normal operation.
(CX, FL, RJ) RX	(Receive) Flashing green LED indicates port is receiving data.
(CX, FL) Link	Steady green LED indicates port is receiving link signal.
Coll(ision)	Flashing green LED indicates port is in a collision state. NOTE: Steady illumination indicates an excessive number of collisions are occurring on the port.
Jab(ber)	Steady green LED indicates a jabber condition.

SWITCH

Coax Config(uration)	Sets internal 10BASE-2 terminator to either 50 ohms or 0 ohms.
-----------------------------	--

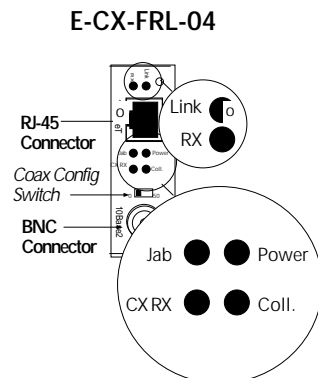
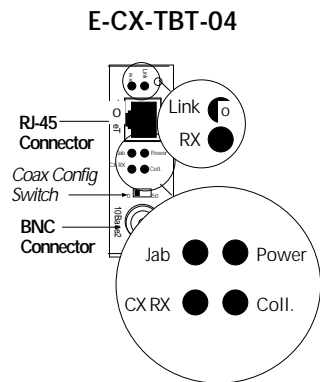

ETHERNET CABLE SPECIFICATIONS

The physical characteristics of the media cable must meet or exceed IEEE 802.3 10BASE-T, 10BASE-2, and/or 10BASE-FL specifications.

Maximum number of media converters in series: 2

10BASE-T CABLE SPECIFICATIONS

Category 3 wire or better is required; category 5 wire is recommended. Either shielded twisted pair (STP) or unshielded twisted pair (UTP) can be used. DO NOT USE FLAT OR SILVER SATIN WIRE.

Category 3:	
Gauge	24 to 22 AWG
Attenuation	28 dB/1000' @ 10 MHz
Differential Characteristic Impedance	100 Ω ±10% @ 10 MHz

Category 5:	
Gauge	24 to 22 AWG
Attenuation	20 dB/1000' @ 10 MHz
Differential Characteristic Impedance	100 Ω ±10% @ 10 MHz

Maximum Cable Distance: 100 meters (330 feet)

10BASE-FL CABLE SPECIFICATIONS

MULTIMODE

Fiber Optic Cable Recommended:	62.5 / 125 μm multimode fiber
Optional:	100 / 140 μm multimode fiber 85 / 125 μm multimode fiber 50 / 125 μm multimode fiber
Fiber Optic Transmitter Power:	Average power: -15.0 dBm Peak power: -12.0 dBm ±1dBm
Fiber Optic Receiver Sensitivity:	Average sensitivity: -27.4 dBm Bit error rate: ≤10 ⁻¹⁰
Maximum Cable Distance:	2000 meters

SINGLEMODE

Fiber Optic Cable Recommended:	9/125 micron single mode fiber
Fiber Optic Transmitter Power:	Typical transmit power: -22.5dBm Best case transmit power: -18.5dBm Worst case transmit power: -28.5dBm
Fiber Optic Receiver Power:	Best case fiber sensitivity: -35dBm Worst case fiber sensitivity: -30dBm Bit error rate: ≤10 ⁻¹⁰
Maximum Cable Distance:	5,000 meters- 20,000 meters

10BASE-2 CABLE SPECIFICATIONS

Cable type:	Stranded Coaxial RG58
Impedance:	50 Ω @ 10 MHz
Mutual Capacitance:	24 pF/ft ±20% @ 10 MHz
Maximum Cable Distance:	185 meters (610 feet)
Maximum number connections:	30
Minimum distance/connection:	0.5 meters (1.6 feet)

MEDIA CONVERTER TROUBLESHOOTING SUGGESTIONS

If a Media Converter fails, ask the following questions:

1. Is the power LED on the media converter illuminated?

NO

- Is the power adapter the proper type of voltage and cycle frequency for your AC outlet? NOTE: Refer to the "Power Supply Requirements" on the back page.
- Is the power adapter properly installed in the media converter and in the outlet?
- Contact Technical Support: (800) 260-1312/(800) LAN-WANS.

YES

- Proceed to step 2.

2. Is the Link LED illuminated?

NO

10BASE-T

- Check UTP cables for proper connection and pin assignment shown in diagram on previous page.
- Is the Link Switch on the media converter set to ON?
- Contact Technical Support: (800) 260-1312/(800) LAN-WANS.

10BASE-2

- Check coax cables for proper connection.
- Check coax cable for opens or shorts. Check and/or replace each BNC "T" connector on the segment, making sure each "T" is attached firmly.
- Verify that coax cables on media converter are terminated properly at both ends. NOTE: In a coax thinnet installation, the first and last device in a daisy-chain are terminated.
- Verify that each 10BASE-2 segment is grounded to earth ground.
- Contact Technical Support: (800) 260-1312/(800) LAN-WANS.

10BASE-FL

- Check fiber cables for proper connection.
- Verify that TX and RX cables on media converter are connected to RX and TX ports, respectively, on the other 10BASE-FL device.
- Refer to Tech Tips available at:
<http://www.transition.com>
- Contact Technical Support: (800) 260-1312/(800) LAN-WANS.

YES

- Contact Technical Support: (800) 260-1312/(800) LAN-WANS.

MEDIA CONVERTER INSTALLATION NOTES

NOTE: The media converter supports 10mbps speeds only.

ALL MEDIA CONVERTERS:

- Install the media converter with the power supply provided. (Output 9 VDC regulated, 500 mA).
- Connect the power supply cable to the media converter BEFORE connecting the power supply cable to the AC outlet.
- Do NOT connect more than two media converters in series.

10BASE-T CONNECTIONS

- Be certain that the 10BASE-T cable is configured correctly for site installation (straight through or crossover), as shown on the next page. NOTE: An RJ-45 telephone cable is reverse-wired, which is NOT the same as a crossover pinout.

10BASE-2 CONNECTIONS

- Ground EACH coax segment to earth ground at one end.
- Set coax configuration switch:
Use 50 ohm switch position when connecting the end of a coax segment DIRECTLY to the media converter's BNC port.
Use 0 ohm switch position when connecting to the middle or in line of a thin coax segment. (For this position a BNC "T" must be connected to the media converter's BNC port).

10BASE-FL CONNECTIONS

NOTE: Fiber connections are full duplex.

- Verify that the fiber products to be connected are 10BASE-FL or FOIRL compliant. NOTE: Fiber ports on TRANSITION Networks fiber media converters conform to 10BASE-FL or FOIRL but NOT to 10BaseFB or FDDI.
- 62.5/125 micron duplex fiber cable is recommended.
- The maximum loss for the fiber cable should not exceed 13 dBm.

MEDIA CONVERTERS in the NETWORK

TRANSITION Networks media converters provide media connections to and from 10BASE-T, 10BASE-2, and 10BASE-FL.

E-CX-TBT requires straight through/crossover 10BASE-T cable configuration.

Configuring 10BASE-T Straight Through/Crossover Cable Assembly

The two active pairs in a 10BASE-T network are pins 1 & 2 and pins 3 & 6. Use only dedicated wire pairs (such as blue/white & white/blue, orange/white & white/orange) for the active pins.

Cable connections between a hub and the media converter must be configured as **straight through**. Cable connections between the media converter and a terminal, transceiver or NIC

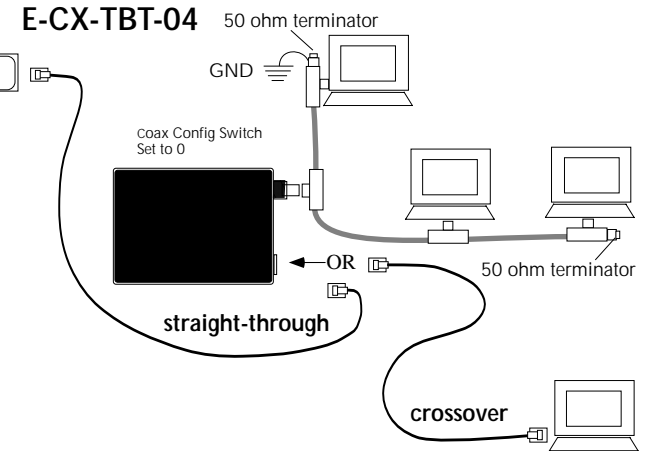
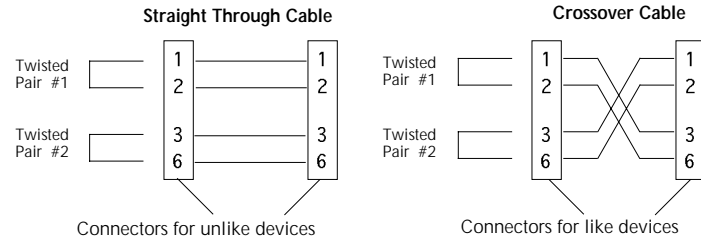

E-CX-TBT and E-CX-FRL both require the coax configuration switch to be set and the coax segment to be grounded.

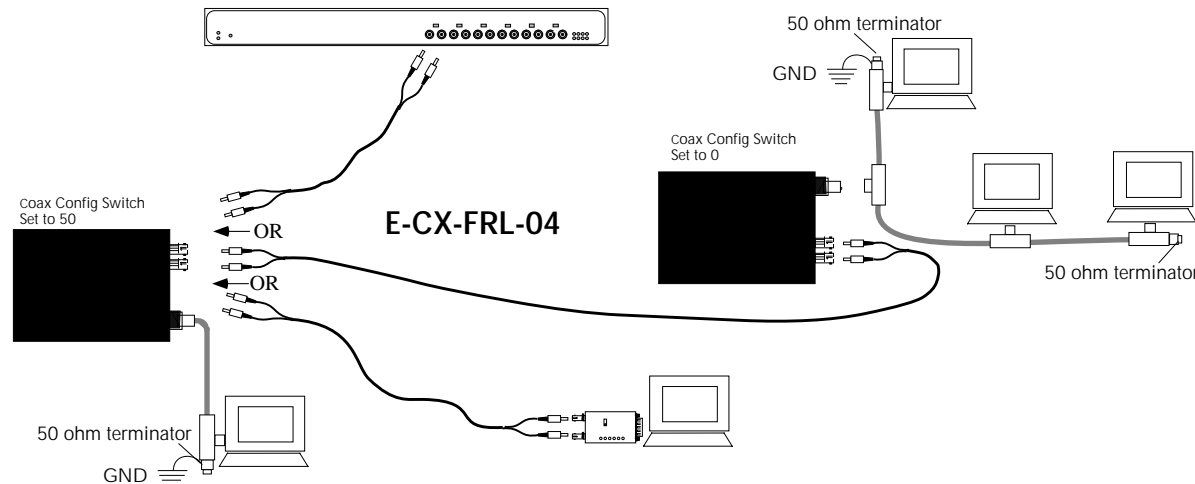

Setting the Coax Configuration Switch:

Set switch position to 50 ohms when connecting the end of a thin coax segment DIRECTLY to the media converter's BNC port. (NOTE: The minimum coax cable length must be 0.5 meters.)

Set switch position to 0 ohms when connecting to the middle or in line of a thin coax segment. (NOTE: For this position a BNC "T" must be connected to the media converter's BNC port).