

PowerStar™ V

1-2 Mb/s Hub for AS400™, S3/x, 5x94 Host

PSV-2/14-45

USER'S GUIDE

COMPLIANCE INFORMATION

UL Listed
C-UL Listed (Canada)
CISPR/EN55022 Class A

FCC Regulations

This equipment has been tested and found to comply with the limits for a class A digital device, pursuant to part 15 of the FCC rules. These limits are designed to provide reasonable protection against harmful interference when the equipment is operated in a commercial environment. This equipment generates, uses, and can radiate radio frequency energy and, if not installed and used in accordance with the instruction manual, may cause harmful interference to radio communications. Operation of this equipment in a residential area is likely to cause harmful interference, in which case the user will be required to correct the interference at the user's own expense.

Canadian Regulations

This digital apparatus does not exceed the Class A limits for radio noise for digital apparatus set out on the radio interference regulations of the Canadian Department of Communications.

Le présent appareil numérique n'émet pas de bruits radioélectriques dépassant les limites applicables aux appareils numériques de la classe A prescrites dans le Règlement sur le brouillage radioélectrique édicté par le ministère des Communications du Canada.

European Regulations

Warning

This is a Class A product. In a domestic environment this product may cause radio interference in which case the user may be required to take adequate measures.

Achtung !

Dieses ist ein Gerät der Funkstörgrenzwertklasse A. In Wohnbereichen können bei Betrieb dieses Gerätes Rundfunkstörungen auftreten, in welchen Fällen der Benutzer für entsprechende Gegenmaßnahmen verantwortlich ist.

Attention !

Ceci est un produit de Classe A. Dans un environnement domestique, ce produit risque de créer des interférences radioélectriques, il appartiendra alors à l'utilisateur de prendre les mesures spécifiques appropriées



CAUTION: RJ connectors are NOT INTENDED FOR CONNECTION TO THE PUBLIC TELEPHONE NETWORK. Failure to observe this caution could result in damage to the public telephone network.

Der Anschluss dieses Gerätes an ein öffentliches Telekommunikationsnetz in den EG-Mitgliedstaaten verstößt gegen die jeweiligen einzelstaatlichen Gesetze zur Anwendung der Richtlinie 91/263/EWG zur Angleichung der Rechtsvorschriften der Mitgliedstaaten über Telekommunikationsendeinrichtungen einschliesslich der gegenseitigen Anerkennung ihrer Konformität.

Trademark Notice

All registered trademarks and trademarks are the property of their respective owners.

Copyright Restrictions

© 1999 TRANSITION Networks.

All rights reserved. No part of this work may be reproduced or used in any form or by any means – graphic, electronic, or mechanical – without written permission from TRANSITION Networks.

Printed in the U.S.A.

33121.A

The TRANSITION Networks rack-mountable PowerStar™ V, PSV-2/14-45, converts a twinax daisy-chain topology to an unshielded twisted-pair star topology in AS/400™, Sys36, or 5x94 remote controller host environments. The PowerStar™ V supports all 5250 compliant devices operating at speeds of either 1 Mb/s OR 2 Mb/s (IBM® 5250 Express*).

PSV-2/14-45

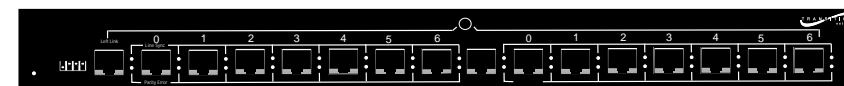

The PowerStar™ V distributes one or two host input signals from the AS/400, Sys36, or 5x94 remote controller, received over twinax, fiber, or twisted-pair media, to up to seven (7) terminal devices for each host input signal (up to fourteen (14) terminal devices for two host input signals).

All signals from the PowerStar™ V to terminal devices are over twisted-pair using RJ-45 port connectors.

PS-T-SIC Optional slide-in-card (SIC) for the TRANSITION Networks PowerStar™ V; when installed, provides two (2) twinax link connections for host input signal(s).

PS-F-SIC Optional slide-in-card (SIC) for the TRANSITION Networks PowerStar™ V; when installed, provides two (2) fiber link connections for host input signal(s).

*Refer to IBM® 5250 Express reference material available from network vendors when installing PowerStar™ V in a 5250 Express network.

PSV-2-14/45 in the Network	2
Installation	4
Operation	12
Cable Specifications	13
Technical Specifications	15
Compliance Information	16

PSV-2/14-45 IN THE NETWORK

The PowerStar™ V allows various host input connection options.

When the PowerStar™ V is within approximately 460 meters (2 Mb/s Express mode) or 760 meters (1 Mb/s standard mode) of the host, the link from the host to the PowerStar™ V can be made by installing a twinax balun at the host and then connecting twisted-pair cable between the twinax balun and one of two RJ-45 *LINK* connectors at the front of the PowerStar™ V. A second connection can be made to the second RJ-45 *LINK* connector.

When the PowerStar™ V is within approximately 1200 meters (2 Mb/s Express mode) or 1520 meters (1 Mb/s standard mode) of the host, if the optional twinax slide-in-card (SIC), PS-T-SIC, is installed in the PowerStar™ V, the link from the host to the PowerStar™ V can be made by connecting twinax cable between the host and one of two (2) twinax connectors on the slide-in-card at the back of the PowerStar™ V. A second connection can be made to the second twinax connector on the slide-in-card.

When the PowerStar™ V is within approximately 3000 meters (2 Mb/s Express mode OR 1 Mb/s standard mode) kilometers of the host, if the optional fiber slide-in-card, PS-T-SIC, is installed in the PowerStar™ V and a compatible twisted-pair/fiber media converter (such as the TRANSITION Networks IBM® 5250) is available, the link from the host to the PowerStar™ V can be made by installing a twinax balun at the host, then connecting twisted-pair cable between the balun and the media converter, and then connecting fiber from the media converter to one of two (2) fiber connectors on the slide-in-card at the back of the PowerStar™ V. A second connection can be made to the second fiber connector on the slide-in-card.

When the PowerStar™ V is within approximately 3000 meters of the host, if the optional twinax slide-in-card is installed in the PowerStar™ V and a compatible twisted-pair/fiber media converter (such as the TRANSITION Networks IBM® 5250) is available, the link from the host to the PowerStar™ V can be made by installing a twinax balun at the host, then connecting twisted-pair cable between the balun and the media converter, connecting fiber from the media converter to a second media converter, installing another twinax balun on the twinax slide-in-card, then connecting twisted-pair cable between the media converter and the balun. A second connection can be made to the second twinax connector on the slide-in-card.

Connection from the PowerStar™ V to terminal devices is through twisted-pair copper cable and RJ-45 connectors.

TECHNICAL SPECIFICATIONS

Host Connection IBM® S/3x (System 34, 36, 38), AS/400™ Host or AS/400™ Controllers

Dimensions 17.0" x 7.5" x 1.7" (432 mm x 191 mm x 43 mm)

Power

Input Range: 85 to 265 VAC at 47 to 63 Hz. Rated at 40 watts maximum.

Power Cord:

TN PN	Requirement	Location
3344	120 volts, 60 hertz	USA/Canada/Mexico
3344	100 volts, 50-60 hertz	Japan
3347	230 volts, 50 hertz	Europe
3348	240 volts, 50 hertz	Australia
3349	240 volts, 50 hertz	United Kingdom

Environment Temperature: 0-50°C (32° to 122° F)
Humidity: 10-95%, non condensing
Altitude: 0-10,000 feet

Storage Temperature -40 to 85C (-40 to 185F)*

*Must be stable within operating environment limits before powering on.

Warranty Lifetime

TRANSITION NETWORKS		DECLARATION OF CONFORMITY
Name of Mfg:	Transition Networks 6475 City West Parkway, Minneapolis MN 55344 USA	
Model:	PowerStar™ V	
Part Number:	PSV-2/14-45	
Regulation:	EMC Directive 89/336/EEC	
Purpose:	To declare that the PSV-2/14-45 to which this declaration refers is in conformity with the following standards. EMC-CISPR 22: 1985 Class A; EN 55022: 1988 Class A; EN 50082-1:1992; EN 60950 A4:1997; IEC 801.2, IEC 801.3, and IEC 801.4; IEC 950	
<i>I, the undersigned, hereby declare that the equipment specified above conforms to the above Directive(s) and Standard(s).</i>		
 Stephen Anderson, Vice-President of Engineering		September 30, 1999 Date

CABLE SPECIFICATIONS (continued)

Fiber Cable and Connector Specifications

MULTIMODE FIBER CABLE

Fiber Optic Cable Recommended:	62.5 / 125 μm multimode fiber	
Optional:	100 / 140 μm multimode fiber	
	85 / 125 μm multimode fiber	
	50 / 125 μm multimode fiber	
Wavelength	850 nM	
Fiber Optic Transmitter Power:	min: -19.0 dBm	max: -14.0 dBm
Fiber Optic Receiver Sensitivity:	min: -24.0 dBm	max: -10.0 dBm

MINIMUM CABLE DISTANCE 7.6 meters (25 feet)

Typical Maximum Cable Distance*: 3 kilometers (10,000 feet)

*Actual distance dependent upon physical characteristics of network installation.

ST CONNECTOR

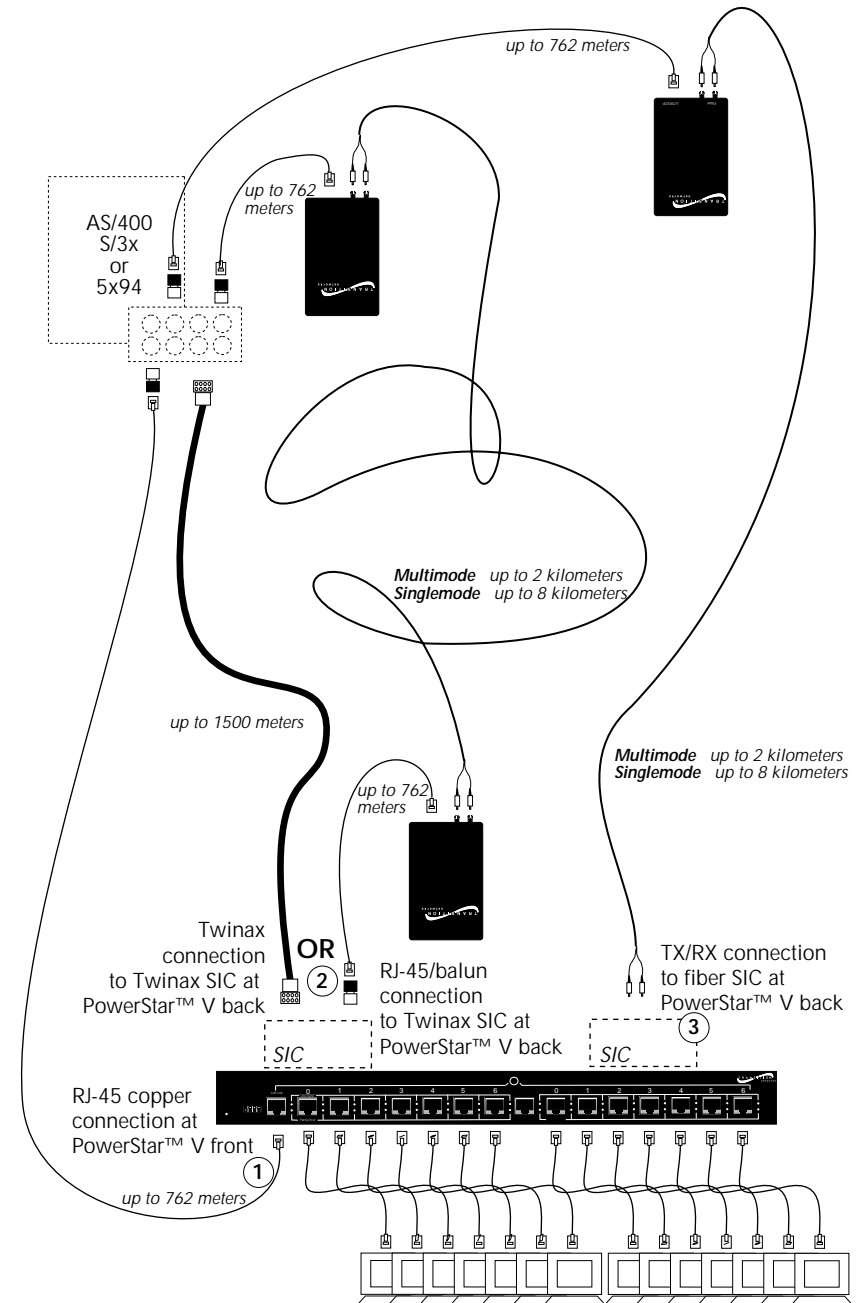

INSTALLATION

Set Twisted-Pair Polarity Switches

Two (2) sets of twisted-pair polarity switches at the PowerStar™ V front toggle the polarity of the active RJ-45 pins for each *host Link* and for each set of seven *device Ports*.

Set the factory default *host Link* switch to "A" when connecting twinax cable to the host.

Set the *host Link* switch and the *device Ports* switch for twisted-pair copper to "A" or to "B" according to the pin settings and baluns (TRANSITION Networks or other) used at the RJ-45 port connectors:

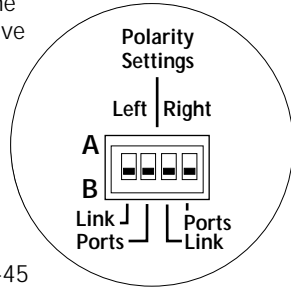

Setting	Pins	TN Balun	NOTE: TRANSITION Networks baluns listed in the table to the left are coded as: "3-XXxx", where XX represents the twisted-pair port connector (45 = RJ-45) and xx represents the order of the active pins (12 = 1 & 2, 21 = 2 & 1, 36 = 3 & 6, 63 = 6 & 3, 45 = 4 & 5, 54 = 5 & 4.
A	2 & 1	3-4521	
A	6 & 3	3-4563	
A	5 & 4	3-4554	
B	1 & 2	3-4512	
B	3 & 6	3-4536	
B	4 & 5	3-4545	

Optionally Install Slide-In-Card (SIC)

CAUTION: Wear a grounding device and observe electrostatic discharge precautions when installing slide-in cards. Failure to observe this caution could result in circuit board failure.

To install a slide-in-card:

1. With slide-in-card components facing up, carefully guide slide-in-card along card guides until connector on slide-in-card meets internal PowerStar™ V edge connector.
2. Firmly push card into slot until slide-in-card faceplate is flat against PowerStar™ V frame.
3. Rotate two slide-in-card thumbscrews into PowerStar™ V threaded holes.

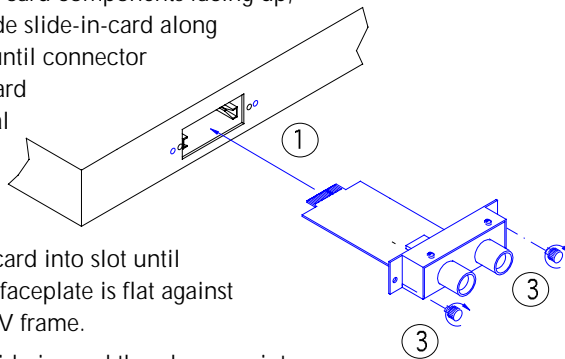

CABLE SPECIFICATIONS

Twisted Pair Cable and Connector Specifications

Category 3 OR BETTER twisted-pair copper wire is required. Either shielded twisted-pair (STP) or unshielded twisted-pair (UTP) can be used. DO NOT USE FLAT OR SILVER SATIN WIRE.

CATEGORY 3 CABLE

Gauge	24 to 22 AWG
Attenuation	-11.5 dB/100m @ 5-10 MHz

MINIMUM CABLE DISTANCE 7.6 meters (25 feet)

Typical Maximum Cable Distance*:

1 Mb/s	760 meters (2500 feet)
2 Mb/s	460 meters (1500 feet)

*Actual distance dependent upon physical characteristics of network installation.

RJ-45 CONNECTOR

Twisted pair connection requires one active pair configured as straight through. Using RJ-45 connectors, the active pair can be pins 1 & 2, pins 4 & 5 or pins 3 & 6.

Twinax Cable and Connector Specifications

TWINAX CABLE

Twinax cable consists of conductors - one tinned and one solid copper - in a tinned copper braid shield, with impedance of 100 ohms.

Cable Type	IBM PN or equivalent
Twinax Plenum	7362061
Twinax PVC	7362211

MINIMUM CABLE DISTANCE 7.6 meters (25 feet)

Typical MAXIMUM CABLE DISTANCE*:

1 Mb/s	1520 meters (5,000 feet)
2 Mb/s	1200 meters (4,000 feet)

*Actual distance dependent upon physical characteristics of network installation.

NOTE: The last twinax connection in a daisy-chain must be terminated.

OPERATION

Use the status LEDs to monitor PowerStar™ V operation in the network.

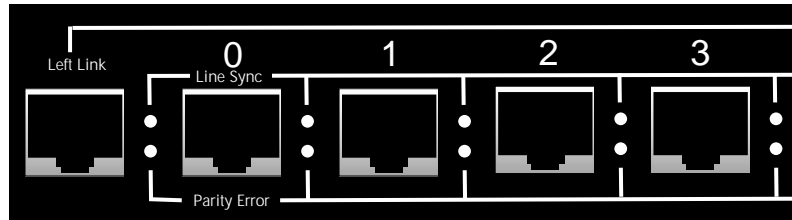

Line Sync	Flashing LED indicates, for each isolated twisted-pair copper port, normal operation in either 1 Mb/s mode or 2 Mb/s (5250 Express) mode.
Parity Error	(1 Mb/s mode) Flashing LED indicates, for each isolated twisted-pair copper port, parity error occurrence. (2 Mb/s – 5250 Express – mode) Flashing LED indicates, for each isolated twisted-pair copper port, normal operation in 5250 Express mode.
Power	Steady LED indicates PowerStar™ V connection to external AC power.

Set Pin Jumpers (ONLY IF NECESSARY)

The default pin setting is two centered jumpers, which activates pins 4 & 5 in the associated RJ-45 connector. Set pin jumpers ONLY if the installation requires activation of pins 1 & 2 or of pins 3 & 6 INSTEAD OF pins 4 & 5.

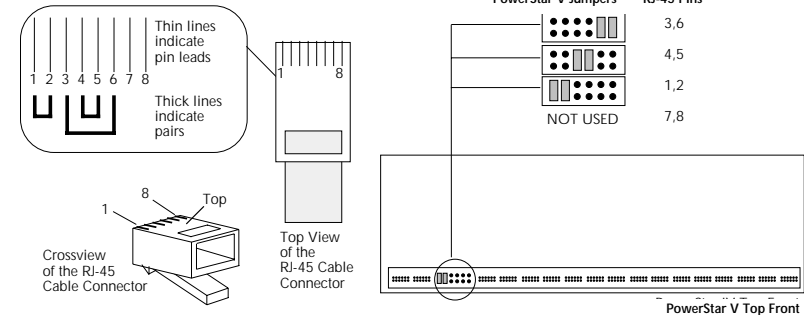
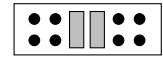

WARNING: DISCONNECT POWER CORD from PowerStar™ V before setting jumper pins. Failure to observe this warning could result in personal injury or death from electrical shock.

WARNING: AVOID CONTACT WITH POWER SUPPLY during jumper pin setting. Failure to observe this warning could result in personal injury or death from electrical shock caused by capacitive discharge.

CAUTION: Wear a grounding device and observe electrostatic discharge precautions when setting pin jumpers. Use needle nosed pliers with insulated handle. Failure to observe this caution could result in circuit board failure.

To verify and/or modify the jumper pin settings:

1. Place PowerStar™ V on table or other stable surface.
2. Using medium Phillips screwdriver, remove and retain three (3) screws that secure cover to PowerStar™ V left side, three (3) screws that secure

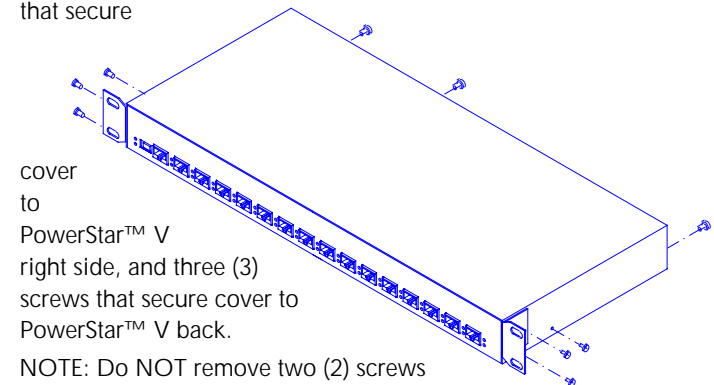

cover to PowerStar™ V right side, and three (3) screws that secure cover to PowerStar™ V back.

NOTE: Do NOT remove two (2) screws that secure power connector.

- To disengage cover from chassis, slide PowerStar™ V cover approximately one-inch toward back of the PowerStar™ V.
- Carefully lift PowerStar™ V cover and remove.
- Using needle nose pliers with insulated handle and referring to reference diagram on the previous page, move jumpers as required to change factory default active pin settings to active pin settings for the site.

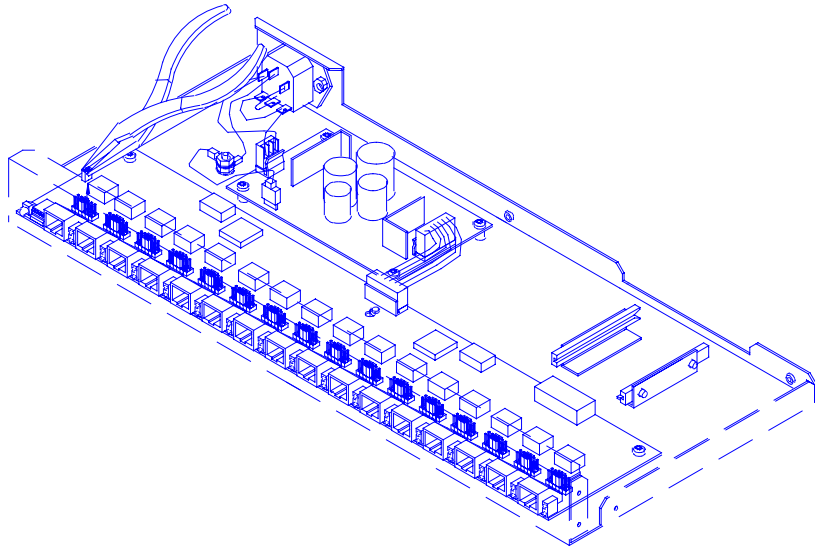

- Replace PowerStar™ V cover on chassis, sliding cover forward to engage cover against chassis.
- Replace retained cover screws.

Power the PowerStar™ V

NOTE: Fuse must be installed at correct setting for power source voltage before connecting to AC outlet.

To power ON the PowerStar™ V:

- At PowerStar™ V back, locate the power receptacle and associated fuse.
- Verify that fuse is installed at correct rating setting for power source voltage. (The installed fuse rating is indicated by the reading at lower right corner of fuse holder.)

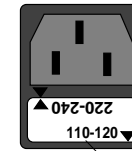

Fuse Holder

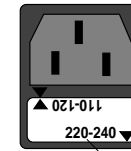

Fuse Holder

110-120 Orientation

220-240 Orientation

If not installed at correct setting for power source voltage:

- Carefully open fuse receptacle, using a small flat blade screwdriver.
 - Rotate fuse holder 180° to the correct rating orientation.
 - Install fuse holder in correct rating orientation.
 - Close fuse receptacle.
- Plug unit end (female) of power cord into PowerStar™ V power receptacle.

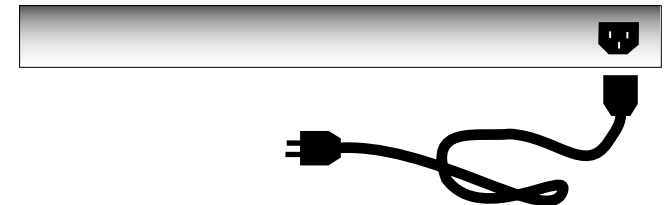

- Plug outlet end (male) of power cord into correct voltage AC wall socket.
- At PowerStar™ V front, verify that **POWER** LED is illuminated.

Connect Port Cable to Terminal Devices

CAUTION: ALL cable lengths MUST be greater than 25 feet (7.6 meters). Failure to observe this caution could cause data transfer to fail.

CAUTION: Terminal devices must be connected to port connectors associated with a host input link signal. Failure to observe this caution will cause data transfer to fail.

NOTE: Set polarity switch (page 3) and – *only if necessary* – configure RJ-45 connector pin settings (page 4).

To connect twisted-pair cable from PowerStar™ V ports to terminal devices:

1. Locate or build twisted-pair cables that conform to specifications on page 13 and to conditions noted above, with minimum length of 25 feet (7.6 meters) and with male RJ-45 connectors installed at both cable ends
2. Connect RJ-45 connector at one end of cable to PowerStar™ V RJ-45 port connector.
3. Connect male RJ-45 connector at other end of cable to terminal device RJ-45 port connector.
4. Repeat steps 1-3 until all terminal devices are connected.

Install PSV-2/14-45 at Site

WARNING: During the site installation, handle the PSV-2/14-45 in such a way that the PSV-2/14-45 does not fall. Failure to observe this warning could result in injury to personnel and/or equipment damage.

NOTE: If PSV-2/14-45 is shipped with brackets installed, proceed to step 2.

To install the PSV-2/14-45 in 19-inch rack cabinet:

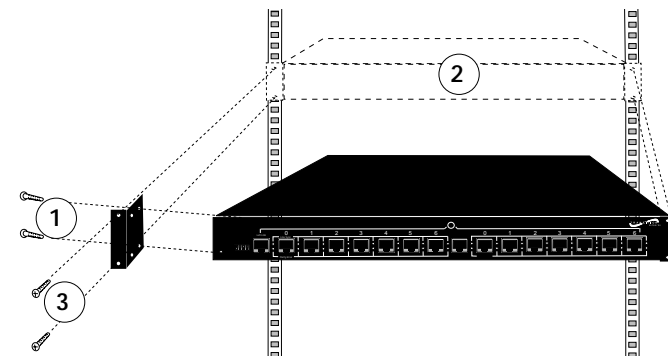

1. Remove and retain two (2) screws located at front left **side** and front right **side** of PSV-2/14-45 chassis. Install right and left front brackets (provided) on PSV-2/14-45 by installing two (2) retained screws through each bracket into chassis.
2. Carefully align the PSV-2/14-45 between 19-inch rack mounting rails.
3. Install PSV-2/14-45 by installing two (2) screws through right front bracket into rack and two (2) screws through left front bracket into rack, using clip nuts (NOT provided) to secure, if necessary.

To install the PSV-2/14-45 on table or other flat surface:

NOTE: Rubber feet are provided.

1. Carefully turn PSV-2/14-45 to side.
2. Install four (4) rubber feet:
 - Separate rubber feet.
 - Remove protective paper from adhesive surface on rubber foot.
 - Position and secure each rubber foot as shown.
3. Return PSV-2/14-45 to upright position.

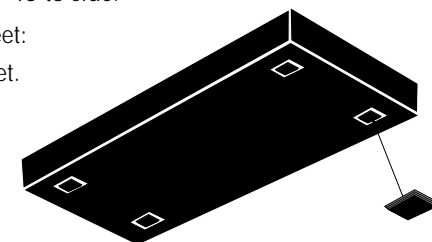

Connect Link Cable to Host

CAUTION: ALL cable lengths MUST be greater than 25 feet (7.6 meters). Failure to observe this caution could cause data transfer to fail.

OPTIONALLY LINK TO HOST USING TWISTED-PAIR CABLE

NOTE: Set polarity switch (page 4), select compatible baluns (page 4), and – *only if necessary* – set RJ-45 pin jumpers (page 5).

CAUTION: Do NOT connect twisted-pair cable to twinax cable by a balun. A mid-link media change may degrade the signal and result in data loss.

NOTE: Twisted-pair link connections provide signals to either the Right Link terminal device RJ-45 port connectors OR to the Left Link terminal device RJ-45 port connectors. If only one twisted-pair link is installed, the choice of connecting to the Right Link or to the Left Link is left to the installer.

To connect link cable to PowerStar™ V RJ-45 link port connectors:

1. Locate or build twisted-pair cable that conforms to specifications on page 13), with male RJ-45 connectors at both cable ends.
2. Install a balun at the AS/400™, Sys36, or 5x94 remote controller twinax port.
3. Install the twisted-pair cable between the balun and the RJ-45 link port connector on the PowerStar V.
4. Optionally connect second twisted-pair cable to second RJ-45 link port connector on PowerStar V., following steps 1 through 3 above..

OPTIONALLY LINK TO HOST USING TWINAX CABLE

NOTE: Twinax link connections, marked on the slide-in-card as Right or Left, provide signals to either the Right Link terminal device RJ-45 port connectors OR to the Left Link terminal device RJ-45 port connectors. If only one twinax link is installed, the choice of connecting to the Right Link or to the Left Link is left to the installer.

To connect twinax cable to PowerStar™ V SIC twinax connector:

1. Be sure that the twinax SIC is installed properly. (See page 4)
2. Locate or build twinax cables that conform to specifications on page 13, with minimum length of 25 feet (7.6 meters) and maximum length of 5000 feet.
3. Connect one end of twinax cable to AS/400, Sys/36, or 5x94 controller port.
4. Connect other end of twinax cable to twinax port connector on slide-in-card.
5. Optionally connect second twinax cable to second twinax port connector on twinax slide-in-card, following steps 2 through 4 above.

OPTIONALLY LINK TO HOST USING FIBER CABLE

NOTE: Fiber link connections, marked on the slide-in-card as Right or Left, provide signals to either the Right Link terminal device RJ-45 port connectors OR to the Left Link terminal device RJ-45 port connectors. If only one fiber link is installed, the choice of connecting to the Right Link or to the Left Link is left to the installer.

To connect fiber cable to PowerStar™ V SIC fiber connector:

1. Be sure that the fiber SIC is installed properly. (See page 4.)
2. Locate one (1) TRANSITION Networks IBM® 5250 PS-CF-01 series media converter (or equivalent) for each fiber connection.
3. Using twinax balun with twisted-pair cable, install TRANSITION Networks IBM® 5250 PS-CF-01 series media converter at AS/400, Sys/36, or 5x94 controller port. (See PS-CF-01 User's Guide for direction.)
4. Locate or build 2-stranded fiber cables that conform to specifications on page 14, with minimum length of 25 feet (7.6 meters) and maximum length of 3,000 meters (10,000 feet), and with male TX/RX connectors at both cable ends.

NOTE: Fiber is installed by connecting one strand of fiber cable to the TX connector on the PS-CF-01 series media converter and to the RX connector on the slide-in-card and by connecting the other strand of the fiber cable to the RX connector on the PS-CF-01 series media converter and to the TX connector on the slide-in-card
5. Connect 2-stranded fiber cable from PS-CF-01 series media converter to fiber port connector on slide-in-card.
6. Optionally connect second 2-stranded fiber cable to second fiber port connector on slide-in-card, following steps 2 through 5 above.

NOTE: As shown in the network drawing on page 3, the twinax SIC card and twinax baluns also can be used with two (2) media converters, such as the TRANSITION Networks IBM® 5250 PS-CF-01, to extend network distances to the PowerStar™ V over twisted-pair copper and fiber. (See PS-CF-01 User's Guide for direction.)